

A
A
All mating joints to be fully welded, preferably TIG with min. ER70 filler material

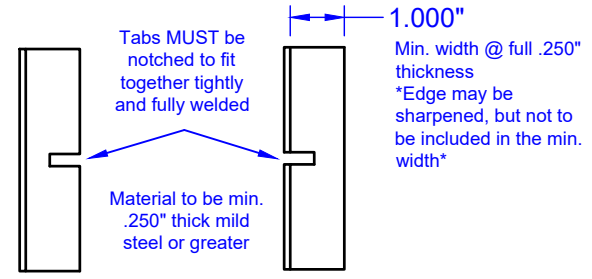
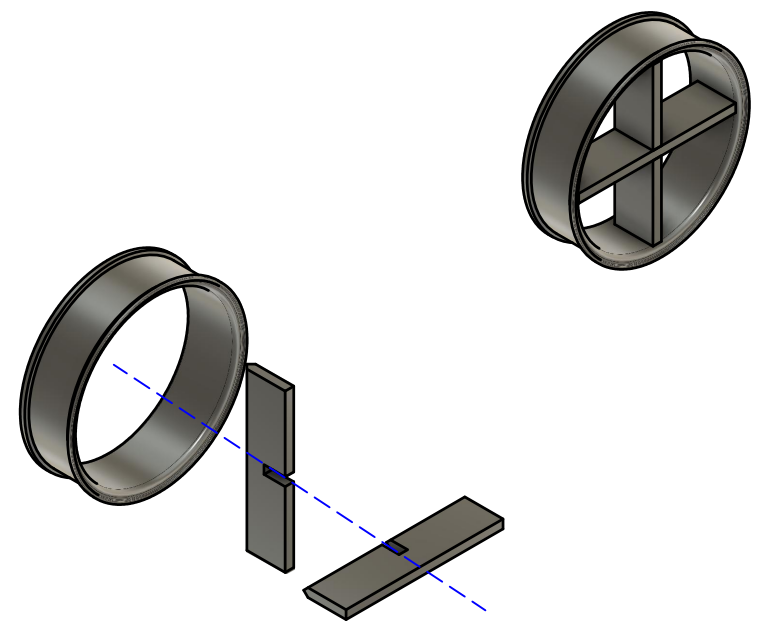
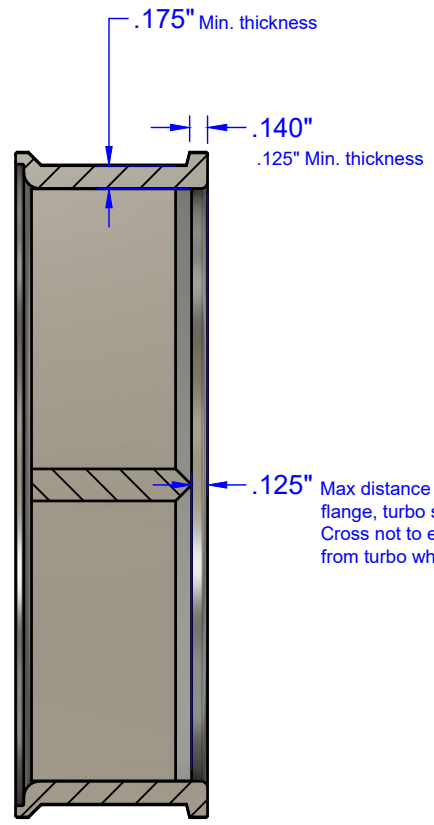

Clamp to turbo housing to be MADE IN THE USA, and clearly marked as such.

ex. Clampco 99506-0525